

MAX LOCK VTN

QUICK COUPLER

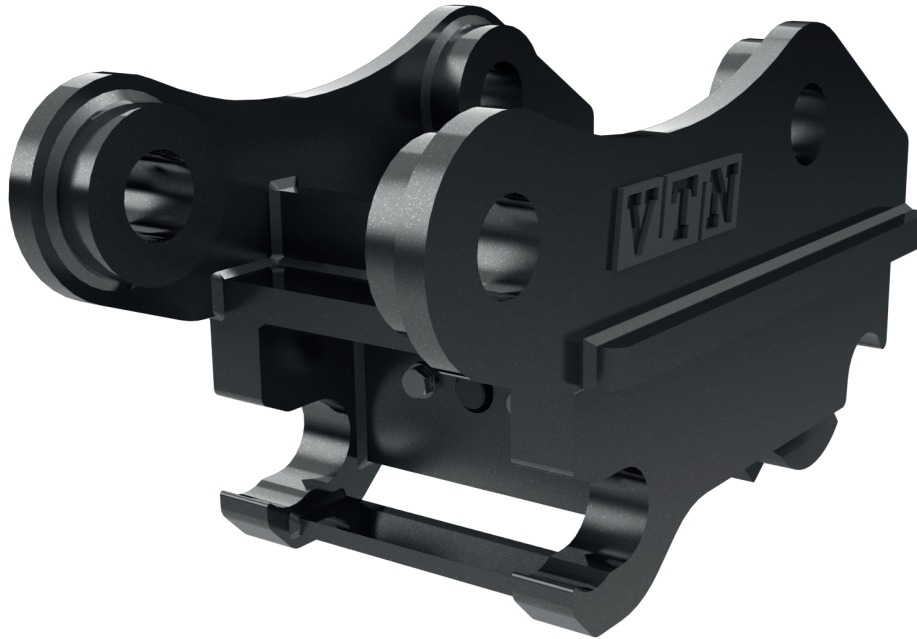

2

The MAX Lock Quick Coupling System has been developed and created by VTN EUROPE in order to respond positively to the New EU norms in matter of reliability and safety for manouvring suspended loads.

MAIN FEATURES:

SAFE: It locks the bucket to the quick coupler even in case of mal-function. The locking system is visible from the operator's cabin thanks to appropriated signals.

REVERSIBLE: It can be fixed to the buckets thanks to the reversible way of coupling. This solution allows operator to work with precision nearby narrow spaces.

DEDICATED: specifically for VTN MAX LOCK Dedicated Buckets.
FAST: It allows Operators to change buckets and type of work in the fastest way thanks to its rapid and effective mechanical and hydraulic system.

HYDRAULIC AND MECHANICAL: Both the versions are available.

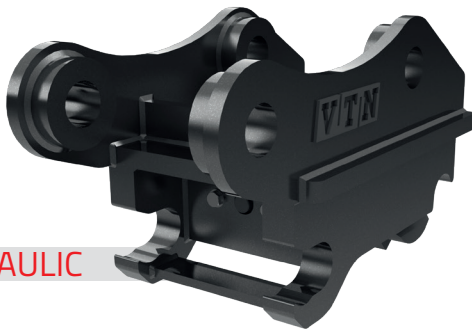

HYDRAULIC



MECHANICAL

CLASS	Ton EXCAVATOR WEGHT	KG	QUICK COUPLER		ADAPTER KIT	
			HYDRAULIC CODE	MECHANICAL CODE	CODE	KG
V20	1,4 > 1,8	29	10RI035	10RM035	APAKAR035	14
V25	1,8 > 2,5	32				
V33	2,5 > 3,8	37				
V38	3,8 > 5,8	71	10RI050	10RM050	APAKAR050	37
V44	5,8 > 10	85				
V49	10 > 12	190	10RI065	N.A.	APAKAR065	104
V55	12 > 15	213				