

CRAWLER EXCAVATOR

HX300AL





READY TO CHANGE YOUR WORLD

The HX300AL Crawler Excavator is part of Hyundai's brand new A-series: a fresh generation of construction equipment that complies with the European stage V emission levels. But it does much more than that! While fulfilling regulatory demands, Hyundai aimed for a ground-breaking level of customer satisfaction with maximum performance and productivity, better safety, more convenience and improved uptime management.

From its robust exterior design to its smart performance-enhancing technologies, the HX300AL opens up a world of new possibilities where tiny efforts move mountains. It's time to experience the Hyundai Effect!

ENTER A WORLD WHERE ANYTHING IS POSSIBLE



Productivity

- Short cycle times
- Mono or two-piece boom
- Electronic Pump Independent Control (EPIC)
- Customisable hydraulic attachment lines
- Attachment flow control (20 tools programmable)
- Fine swing control (option)
- Boom floating system (option)

Serviceability

- Excellent accessibility
- Electric fuel filler pump with automatic stop function
- Centralised greasing (option)
- Hi Mate telematic system
- Extended service intervals

Durability/Safety

- Excellent visibility
- AAVM camera system (option)
- LED lights (option)
- Reinforced upper and lower structure
- High-grade hoses
- Reinforced pins, bushings and polymer shims
- Swing lock (option)

Comfort

- Spacious cabin
- 8" touchscreen monitor
- Automatic climate control
- Smart key and start/stop button
- Air suspension seat with heater (option)
- Viscous cab suspension mounts
- Ergonomic joystick design

POWER AND EFFICIENCY TO MAKE YOU MORE PRODUCTIVE

The HX300AL is powered by a robust Stage V-certified Cummins engine with an innovative integrated after-treatment system that reduces both emissions and maintenance requirements. It delivers all the power you need to handle demanding jobs, along with fast levelling and truck loading times and excellent fuel economy.

A range of smart technologies are included for precise management of the engine output and pump flow rate. A new EPIC (Electronic Pump Independent Control) system improves efficiency through computerised individual control of the hydraulic pumps. Additional features optimise operation and monitoring to enhance productivity every single day.

EPIC (Electronic Pump Independent Control) improves fuel efficiency while maintaining productivity through computerised individual control of hydraulic pumps. The system helps to reduce losses in hydraulic flow and maximise production capacity.

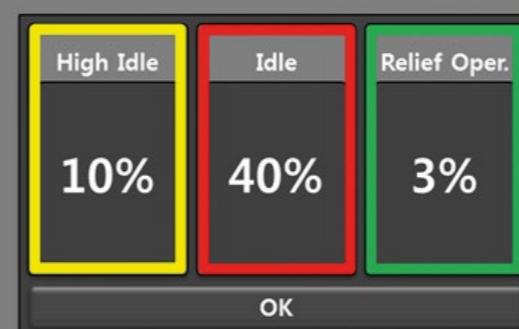
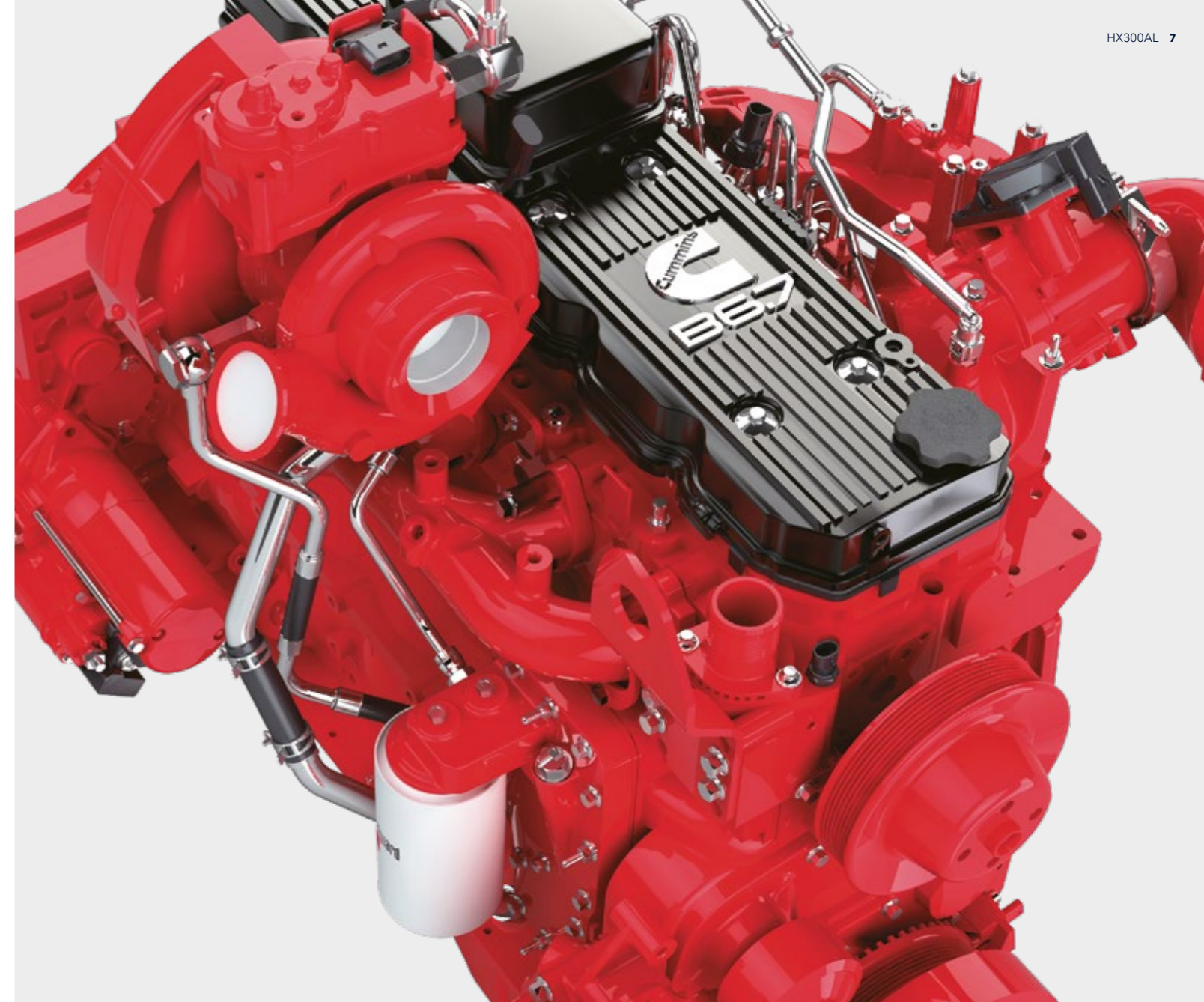
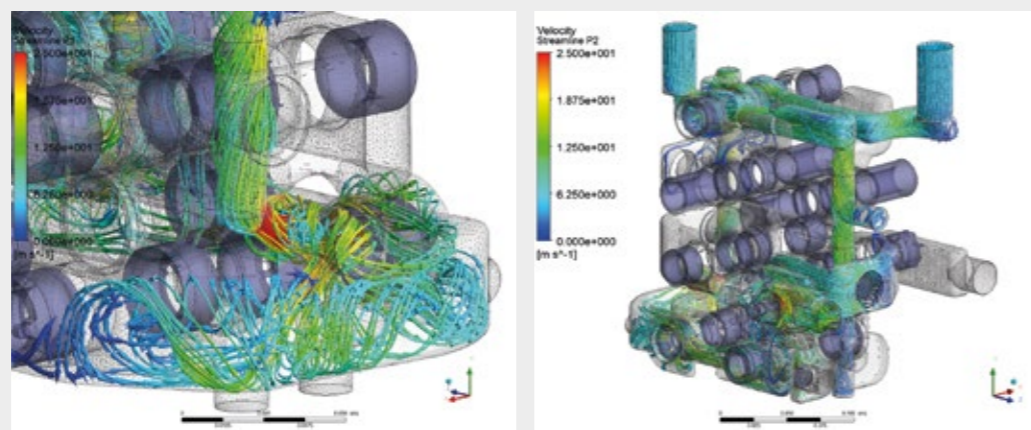

“I’m saving on fuel and reducing emissions without having to compromise on productivity!”

The **Eco Report** feature helps you to develop efficient working habits by displaying real-time information about machine performance.

Like all A-Series machines, the HX300AL features our **all-in-one exhaust aftertreatment system** which cuts emissions and operating costs while enhancing reliability and simplifying maintenance.

Easy-to-use **3D Machine Guidance** gives precise feedback on the bucket position as well as 3D grading assistance and jobsite mapping in real time. This reduces manpower requirements on site and enhances operator performance. The system includes an optional **Hyundai Ready automatic surveying system** for excavators which provides work guides to further improve work speed and productivity.

Productivity Improvement

Work Time Reduction

Leveling Cost Reduction

Safety Improvement

A CABIN DESIGNED AROUND YOU

The HX300AL cabin was designed as a comfortable working environment that enhances productivity and reduces fatigue for every operator. Pleasant and spacious, it features a high-quality, adjustable seat and comfortable reach to all controls. A range of technologies enable easier machine monitoring, while the audio system includes radio, USB and AUX input to keep you entertained during your working day. The overall design places you right at the centre of the Hyundai Effect, with a world of convenience and control at your fingertips.

"I have a complete overview of machine status so I can adapt my performance for better results."



◀ The **instrument panel** is optimised to provide quick, easy access to machine status information as you work. It features an 8-inch **touchscreen monitor** for excellent legibility.

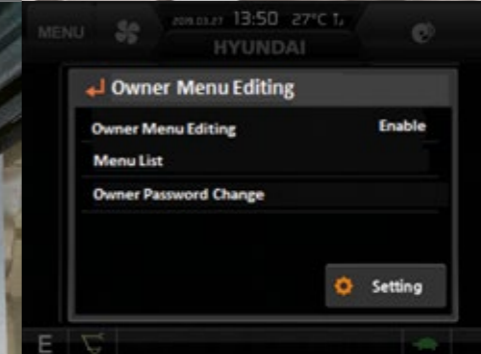

◀ **Menu functions** can be set by the machine owner, who can also provide or restrict access for machine users by using a password to lock or unlock the list.



◀ The HX300AL has a luxurious **air suspension seat with heating** as standard. The **ergonomic joystick** makes operation comfortable and intuitive.



◀ The **heating and air conditioning** system efficiently regulates and directs airflow in the cabin.

◀ The **Miracast system based on the operator's smartphone Wi-Fi** allows the use of various smartphone features on the screen, including navigation, web surfing and music and video playback.



PROTECTION FOR CO-WORKERS AND MACHINERY

Small details can make a huge difference when it comes to safety and security. The HX300AL offers all-round protection for you, your workmates and your equipment. Its cab and engine hood feature a new design that allows maximum visibility, while

All-Around View Monitoring (AAVM) gives you a clear overview of your surroundings. By helping to ensure an accident-free worksite, the HX300AL contributes to the peace of mind and productivity that form part of the Hyundai Effect.

The **All-Around View Monitoring (AAVM)** camera system gives you a 360° overview of your immediate working environment. It also includes Intelligent Moving Object Detection (IMOD) technology that senses and warns you when people or objects come within five metres of the machine.

The **open design of the cabin side door** gives the operator a clear, unimpeded view to the exterior. The **door handle** design has also been redesigned for more convenient access.



"I can always see what's going on around me, even when weather conditions are poor or the machine is moving."



The **auto safety lock** feature prevents unintentional ignition. While the auto safety lock is activated, the excavator is not controlled by the RCV lever.

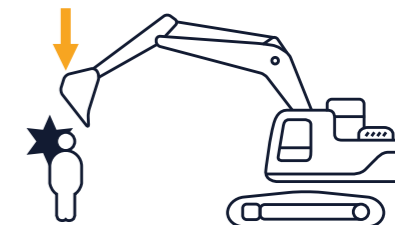
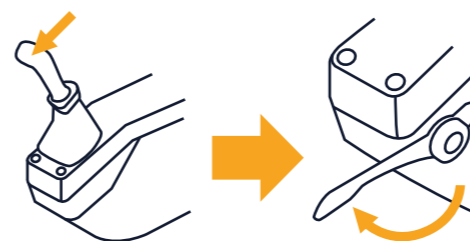

ADVANCED DIAGNOSTICS AND SERVICING SUPPORT

The peace of mind that comes with quick, low-effort servicing is also part of the Hyundai Effect. The HX300AL is designed to make maintenance as convenient as possible. All components and materials have been optimised to ensure a long, trouble-free life. Hyundai's Hi Mate remote management system uses GPS satellite technology to provide the highest level of service and support. The HX300AL also features our new Engine Connected Diagnostics (ECD) system which immediately reports any engine failure to both Hi Mate and the engine manufacturer to ensure the fastest, easiest resolution.

HiMATE

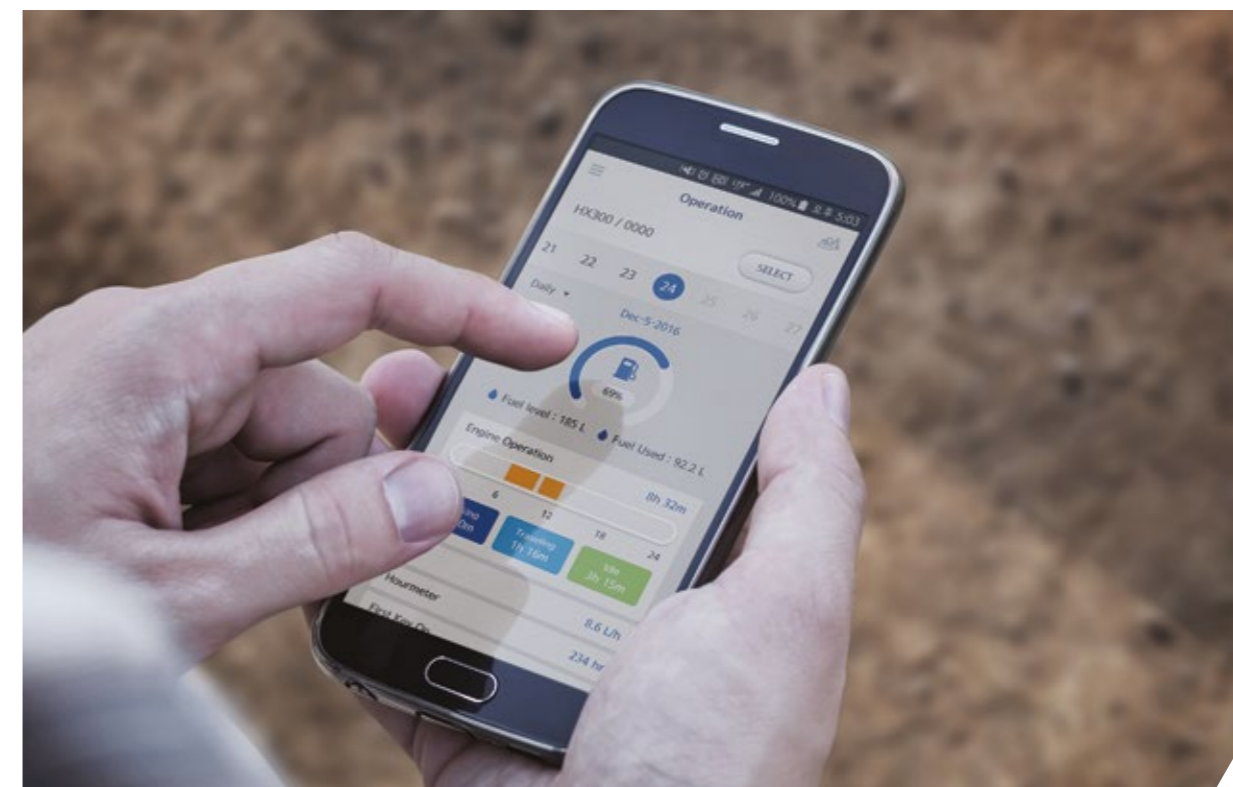

For maximum convenience and security, the HX300AL features Hyundai's exclusive Hi Mate remote fleet management system, which uses mobile data technology to provide the highest level of service and support. You can monitor your machines from any location via a dedicated website or mobile app, with access to working parameters like total engine hours, machine utilisation, actual performed working hours and fuel consumption and machine location. The system makes it easy to evaluate machine productivity and plan servicing and maintenance tasks, as well as any required cost saving measures. It also offers geofencing to protect your machines against theft and unauthorised usage.



"I have a constant overview of performance and maintenance requirements - plus advice and support whenever I need it."

ECD (Engine Connected Diagnostics) provides troubleshooting advice as well as tailored servicing and parts support from Cummins Quick Serve. Service technicians are supported with remote diagnostics reports allowing them to prepare for site visits and bring the right tools.



READY FOR ACTION AND BUILT TO LAST

You need to know that the investment you make today will help to sustain your business over the long term. That's why we prioritised reliability throughout the development of the HX300AL, from design and manufacturing to quality control. We improved engine reliability by integrating exhaust after-treatment and replacing EGR with a simplified, single-module system that's easier to maintain. The upper and lower frame structures are reinforced for high load work, while the attachments have been rigorously tested for the roughest conditions. The overall aim is to minimise downtime and repairs so that you can stay on schedule, avoid unexpected costs and protect your profits.



“Every detail has been reviewed and revised for reliable long-term performance. It means I can keep my promises and have better control of my equipment costs.”

The engine and **exhaust after-treatment** system are integrated for simplified control and maintenance.



High-grade hoses with outstanding resistance to heat and pressure provide maximum durability, even in rough working conditions.

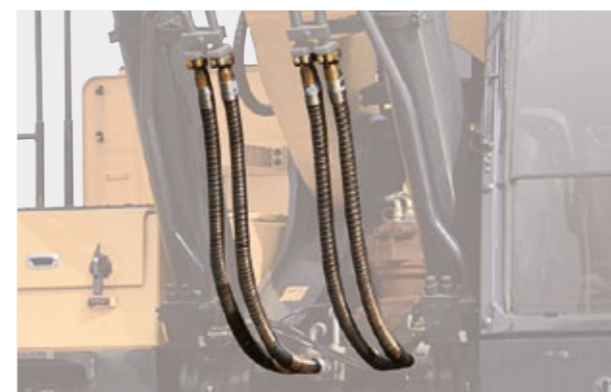

The reinforced **pins, bushings and polymer shims** are designed for an extended lifetime.



FOCUSED TECHNOLOGIES FOR THE RESULTS YOU WANT

Hyundai's crawler excavators are designed to create better conditions for operators and deliver the ultimate ownership experience. Every detail is carefully fine-tuned to match your needs in the field, including better safety and comfort, higher productivity, maximum uptime and easy servicing. It's all part of the Hyundai Effect.

Explore the range at hyundai-ce.eu



SPECIFICATIONS

ENGINE			
Maker / Model	Cummins B6.7 / STAGE V		
Type	4-cycle turbocharged, charge air cooled diesel engine		
Rated Flywheel Horse Power	SAE	J1,995 (Gross)	260 HP (194 kW) at 2,200 rpm
		J1,349 (Net)	255 HP (190 kW) at 2,200 rpm
	DIN	6,271/1 (Gross)	264 PS (194 kW) at 2,200 rpm
		6,271/1 (Net)	259 PS (190 kW) at 2,200 rpm
Max. Power	265 HP (198 kW) at 2,000 rpm		
Max. Torque	138 kgf·m (966 lbf·ft) at 1,500 rpm		
Bore X Stroke	107 x 124 mm (4.21" x 4.88")		
Piston Displacement	6,700 cc (409 cu in)		
Batteries	2 x 12 V x 160 Ah		
Starting Motor	Denso 24 V-4.8 kW		
Alternator	Denso 24 V-95 A		

HYDRAULIC SYSTEM	
MAIN PUMP	
Type	Variable displacement tandem axis piston pumps
Max. Flow	2 x 285 l/min (75.3 U.S. gpm / 62.7 U.K. gpm)
Sub-Pump For Pilot Circuit	Gear pump
Cross-sensing and fuel saving pump system.	

HYDRAULIC MOTORS	
Travel	Variable displacement axial piston motor
Swing	Axial piston motor

RELIEF VALVE SETTING	
Implement Circuits	350 kgf/cm ² (4,980 psi)
Travel	350 kgf/cm ² (4,980 psi)
Power Boost (Boom, Arm, Bucket)	380 kgf/cm ² (5,400 psi)
Swing Circuit	300 kgf/cm ² (4,270 psi)
Pilot Circuit	40 kgf/cm ² (570 psi)
Service Valve	Installed

HYDRAULIC CYLINDERS	
No. of Cylinder Bore X Stroke	Boom: Ø140 x 1,465 mm
	Arm: Ø150 x 1,765 mm
	Bucket: Ø135 x 1,185 mm

DRIVING AND BRAKING	
Drive Method	Fully hydrostatic type
Drive Motor	Axial piston motor, in-shoe design
Reduction System	Planetary reduction gear
Max. Drawbar Pull	27,405 kgf (60,417 lbf)
Max. Travel Speed (High / Low)	6.1 km/hr (3.8 mph) / 3.4 km/hr (2.1 mph)
Gradeability	35° (70%)
Parking Brake	Multi wet disc

CONTROL	
Pilot pressure operated joysticks and pedals with detachable lever provide almost effortless and fatigueless operation.	
Pilot control	Two joysticks with one safety lever (LH): swing and arm, (RH): Boom and bucket
Traveling and Steering	Two levers with pedals
Engine Throttle	Electric, dial type

SWING SYSTEM	
Swing Motor	Fixed displacement axial piston motor
Swing Reduction	Planetary gear reduction
Swing Bearing Lubrication	Grease-bathed
Swing Brake	Multi wet disc
Swing Speed	11.2 rpm

COOLANT & LUBRICANT CAPACITY			
	liter	US gal	UK gal
Fuel tank	500	132.1	110
Engine coolant	42	11.1	9.3
Engine oil	24.4	6.4	5.4
Swing Device	11	2.9	2.4
Final Drive (Each)	7.8	2.06	1.72
Hydraulic system (including tank)	330	87.2	72.6
Hydraulic tank	190	50.2	41.8
DEF/AdBlue®	70	18.5	15.5

UNDERCARRIAGE	
The X-leg type center frame is integrally welded with reinforced box-section track frames. The undercarriage includes lubricated rollers, idlers, track adjusters with shock absorbing springs and sprockets, and a track chain with double or triple grouser shoes.	
Center frame	X - leg type
Track frame	Pentagonal box type
Number of Shoes on each side	48 EA
Number of Carrier Rollers on each side	2 EA
Number of Track Rollers on each side	9 EA
Number of Rail Guards on each side	2 EA

OPERATING WEIGHT (APPROXIMATE)				
Shoes		Operating weight		Ground pressure
Type	Width mm (in)	kg (lb)		kgf/cm ² (psi)
Triple grouser	600 (24")	HX300AL	30,520 (67,290)	0.59 (8.35)
		HX300AL 2pcs boom	33,670 (74,230)	0.65 (9.22)
		HX300A NL	30,400 (67,020)	0.59 (8.32)
		HX300A NL 2pcs boom	33,550 (73,970)	0.65 (9.18)
	700 (28")	HX300AL	31,080 (68,520)	0.51 (7.29)
		HX300AL 2pcs boom	34,230 (75,460)	0.56 (8.03)
		HX300AL	31,450 (69,340)	0.45 (6.46)
	800 (32")	HX300AL 2pcs boom	34,600 (76,280)	0.50 (7.10)
		HX300AL Long Reach	33,590 (74,050)	0.48 (6.90)
	900 (36")	HX300AL	31,840 (70,200)	0.41 (5.85)
HX300AL 2pcs boom		34,990 (77,140)	0.45 (6.39)	
Double grouser	700 (28")	HX300A HW	34,810 (76,740)	0.57 (8.15)

AIR CONDITIONING SYSTEM	
The air condition system for the machine contains the fluorinated greenhouse gas with global warming potential of R134a. (Global Warming Potential: 1,430) The system holds 0.8 kg refrigerant consisting of a CO ₂ equivalent of 1.14 metric tonnes. For more information, Please refer to the manual.	

DIMENSIONS & WORKING RANGE

HX300AL / HX300ANL DIMENSIONS

6.25 m (20' 6") BOOM and 2.1 m (6' 11"), 2.5 m (8' 2"), 3.05 m (10' 0"), 3.75 m (12' 4") ARM

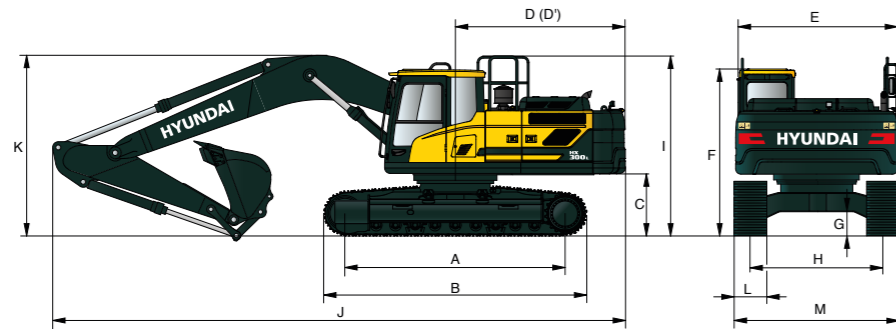

Unit : mm (ft in)

A	Tumbler distance	3,650 (12' 0")
B	Overall length of crawler	4,404 (14' 4")
C	Ground clearance of counterweight	1,060 (3' 6")
D	Tail swing radius	2,890 (9' 5")
D'	Rear-end length	2,770 (9' 1")
E	Overall width of upperstructure	2,740 (9' 0")
F	Overall height of cabin	3,000 (9' 8")
G	Min. ground clearance	480 (1' 7")
H	Track gauge	HX300AL 2,600 (8' 6") HX300ANL 2,390 (7' 10")
I	Overall height of guardrail	3,335 (10' 11")

Boom length		6,250 (20' 6")			
Arm length		2,100 (6' 11")	2,500 (8' 2")	3,050 (10' 0")	3,750 (12' 4")
J	Overall length	10,750 (35' 3")	10,700 (35' 1")	10,600 (34' 9")	10,670 (35' 0")
K	Overall height of boom	3,720 (12' 2")	3,560 (11' 8")	3,320 (10' 11")	3,570 (11' 9")
L	Track shoe	Triple grouser			
	width	600 (1' 12")	700 (2' 4")	800 (2' 7")	900 (2' 11")
M	Overall width	HX300AL 3,200 (10' 6")	3,300 (10' 10")	3,400 (11' 1")	3,500 (11' 5")
		HX300ANL 2,990 (9' 10")	-	-	-

DIMENSIONS & WORKING RANGE

HX300AL LONG REACH DIMENSIONS

10.2 m (33' 6") BOOM and 7.85 m (25' 9") ARM

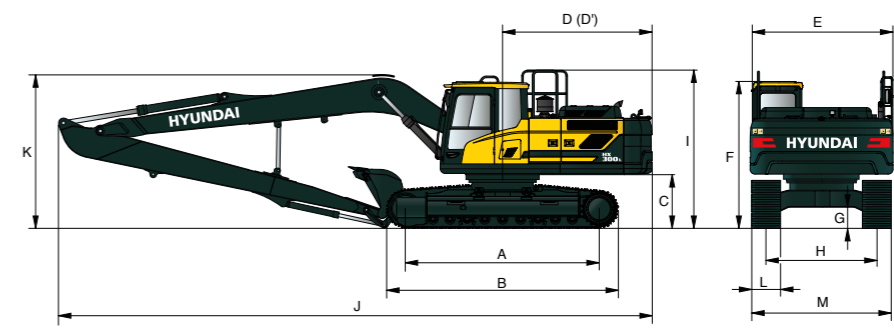

Unit : mm (ft in)

A	Tumbler distance	4,030 (13' 3")
B	Overall length of crawler	4,940 (16' 2")
C	Ground clearance of counterweight	1,185 (3' 9")
D	Tail swing radius	3,210 (10' 5")
D'	Rear-end length	3,120 (10' 3")
E	Overall width of upperstructure	2,980 (9' 9")
F	Overall height of cabin	3,130 (10' 3")
G	Min. ground clearance	500 (1' 8")
H	Track gauge	2,600 (8' 6")
I	Overall height of guardrail	3,335 (10' 9")

Boom length		10,200 (33' 6")
Arm length		7,850 (25' 9")
J	Overall length	14,600 (47' 11")
K	Overall height of boom	3,560 (11' 8")
L	Track shoe width	800 (2' 7")
M	Overall width	3,400 (11' 2")

HX300AL / HX300ANL WORKING RANGE

Unit : mm (ft in)

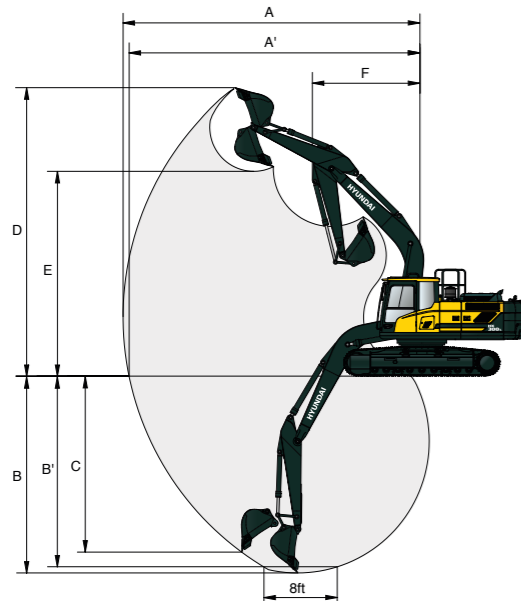

Boom length		6,250 (20' 6")			
Arm length		2,100 (6' 11")	2,500 (8' 2")	3,050 (10' 0")	3,750 (12' 4")
A	Max. digging reach	10,040 (32' 11")	10,310 (33' 10")	10,810 (35' 6")	11,420 (37' 6")
A'	Max. digging reach on ground	9,820 (32' 3")	10,100 (33' 2")	10,610 (34' 10")	11,230 (36' 10")
B	Max. digging depth	6,380 (20' 11")	6,780 (22' 3")	7,330 (24' 1")	8,030 (25' 4")
B'	Max. digging depth (8' level)	6,180 (20' 3")	6,600 (21' 8")	7,170 (23' 6")	7,890 (25' 11")
C	Max. vertical wall digging depth	5,910 (19' 5")	5,760 (18' 11")	6,280 (20' 7")	6,990 (22' 11")
D	Max. digging height	10,130 (33' 3")	9,980 (32' 9")	10,200 (33' 6")	10,410 (34' 2")
E	Max. dumping height	6,990 (22' 11")	6,930 (22' 9")	7,150 (23' 5")	7,360 (24' 2")
F	Min. front swing radius	4,420 (14' 6")	4,320 (14' 2")	4,270 (14' 0")	4,220 (13' 10")

HX300AL / HX300ANL LONG REACH WORKING RANGE

Unit : mm (ft in)

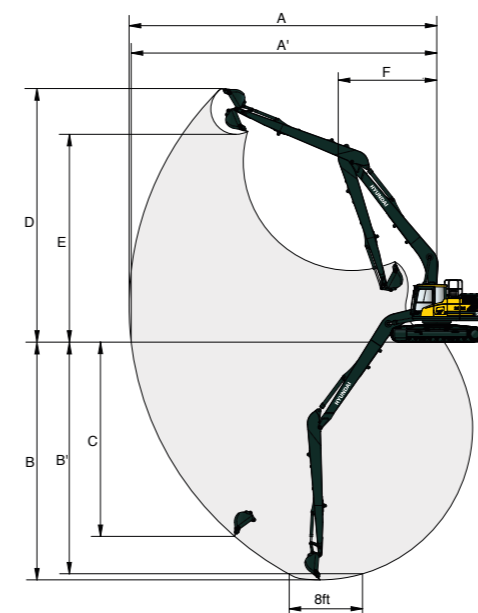

Boom length		10,200 (33' 6")
Arm length		7,850 (25' 9")
A	Max. digging reach	18,530 (60' 10")
A'	Max. digging reach on ground	18,410 (60' 5")
B	Max. digging depth	14,740 (48' 4")
B'	Max. digging depth (8' level)	14,660 (48' 1")
C	Max. vertical wall digging depth	13,700 (44' 11")
D	Max. digging height	14,590 (47' 10")
E	Max. dumping height	12,270 (40' 3")
F	Min. front swing radius	6,270 (20' 7")

DIMENSIONS & WORKING RANGE

HX300AL HIGH WALKER DIMENSIONS

6.25 m (20' 6") BOOM and 2.1 m (6' 11"), 2.5 m (8' 2"), 3.05 m (10' 0"), 3.75 m (12' 4") ARM

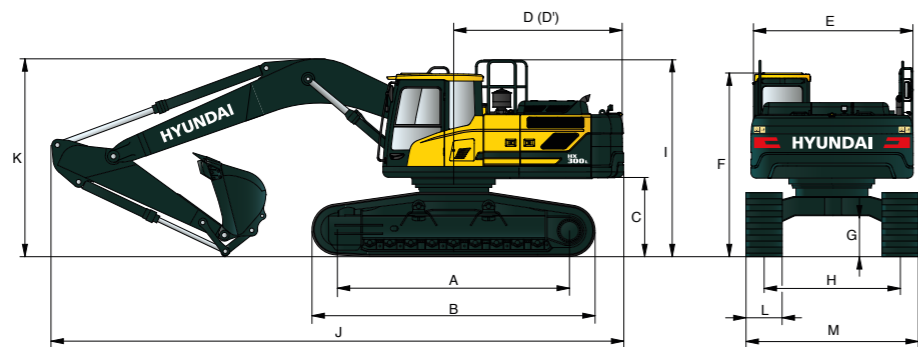

Unit : mm (ft in)

A	Tumbler distance	4,030 (13' 3")
B	Overall length of crawler	4,940 (16' 2")
C	Ground clearance of counterweight	1,490 (4' 9")
D	Tail swing radius	3,210 (10' 5")
D'	Rear-end length	3,120 (10' 3")
E	Overall width of upperstructure	2,980 (9' 9")
F	Overall height of cabin	3,430 (11' 9")
G	Min. ground clearance	765 (2' 6")
H	Track gauge	2,870 (9' 5")
I	Overall height of guardrail	3,640 (11' 9")

Boom length		6,250 (20' 6")				10,200 (33' 6")
Arm length		2,100 (6' 11")	2,500 (8' 2")	3,050 (10' 0")	3,750 (12' 4")	7,850 (25' 9")
J	Overall length	10,730 (35' 2")	10,640 (34' 11")	10,450 (34' 3")	10,530 (34' 7")	14,470 (47' 6")
K	Overall height of boom	3,830 (12' 7")	3,660 (12' 0")	3,440 (11' 3")	3,540 (11' 7")	3,610 (11' 10")
L	Track shoe	Type	Double grouser			
		Width	700 (2' 4")			
M	Overall width	3,570 (11' 9")				

HX300AL HIGH WALKER WORKING RANGE

Unit : mm (ft in)

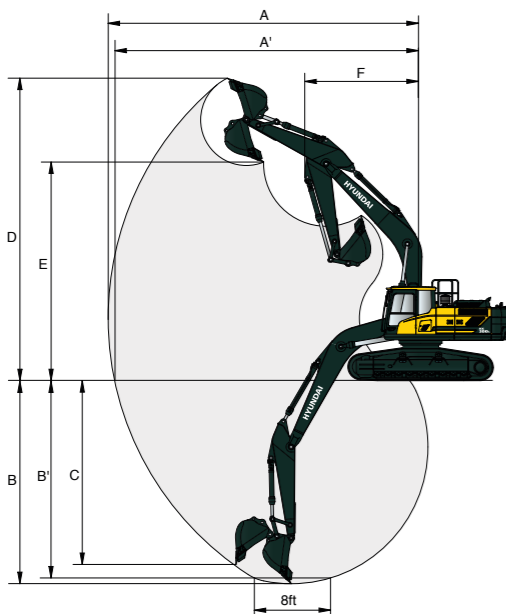

Boom length		6,250 (20' 6")				10,200 (33' 6")
Arm length		2,100 (6' 11")	2,500 (8' 2")	3,050 (10' 0")	3,750 (12' 4")	7,850 (25' 9")
A	Max. digging reach	10,040 (32' 11")	10,310 (33' 10")	10,810 (35' 6")	11,420 (37' 6")	18,530 (60' 10")
A'	Max. digging reach on ground	9,750 (32' 0")	10,020 (32' 10")	10,540 (34' 7")	11,170 (36' 8")	18,370 (60' 3")
B	Max. digging depth	6,060 (19' 11")	6,460 (21' 2")	7,330 (24' 1")	7,710 (25' 4")	14,420 (47' 4")
B'	Max. digging depth (8' level)	5,860 (19' 3")	6,280 (20' 7")	7,170 (23' 6")	7,570 (24' 10")	14,340 (47' 1")
C	Max. vertical wall digging depth	5,590 (18' 4")	5,440 (17' 10")	6,280 (20' 7")	6,670 (21' 11")	13,380 (43' 11")
D	Max. digging height	10,450 (34' 3")	10,300 (33' 10")	10,200 (33' 6")	10,730 (35' 2")	14,910 (48' 11")
E	Max. dumping height	7,320 (24' 0")	7,250 (23' 9")	7,150 (23' 5")	7,680 (25' 2")	12,590 (41' 4")
F	Min. front swing radius	4,420 (14' 6")	4,320 (14' 2")	4,270 (14' 0")	4,220 (13' 10")	6,270 (20' 7")

DIMENSIONS & WORKING RANGE

HX300AL / HX300A NL 2-PIECE BOOM DIMENSIONS

6.25 m (20' 6") 2-Piece BOOM and 2.1 m (6' 11"), 2.5 m (8' 2"), 3.05 m (10' 0"), 3.75 m (12' 4") ARM

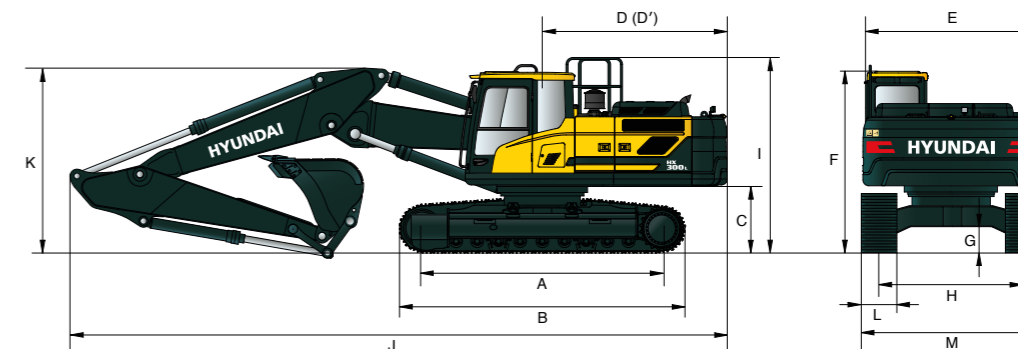

Unit : mm (ft in)

A	Tumbler distance	4,030 (13' 3")	
B	Overall length of crawler	4,940 (16' 2")	
C	Ground clearance of counterweight	1,185 (3' 9")	
D	Tail swing radius	3,210 (10' 5")	
D'	Rear-end length	3,120 (10' 3")	
E	Overall width of upperstructure	2,980 (9' 9")	
F	Overall height of cabin	3,130 (10' 3")	
G	Min. ground clearance	500 (1' 8")	
H	Track gauge	HX300AL	2,600 (8' 6")
		HX300ANL	2,390 (7' 10")
I	Overall height of guardrail	3,335 (10' 11")	

Boom length		6,250 (20' 6")			
Arm length		3,050 (10' 0")	2,500 (8' 2")	3,050 (10' 0")	3,750 (12' 4")
J	Overall length	10,740 (35' 3")	10,700 (35' 1")	10,650 (34' 11")	10,670 (35' 0")
K	Overall height of boom	3,510 (11' 6")	3,420 (11' 3")	3,290 (10' 10")	3,580 (11' 9")
L	Track shoe width	Triple grouser			
		600 (1' 12")	700 (2' 4")	800 (2' 7")	900 (2' 11")
M	Overall width	HX300AL	3,200 (10' 6")	3,300 (10' 10")	3,400 (11' 2")
		HX300ANL	2,980 (9' 9")	-	-

HX300AL / HX300A NL 2-PIECE BOOM DIMENSIONS WORKING RANGE

Unit : mm (ft in)

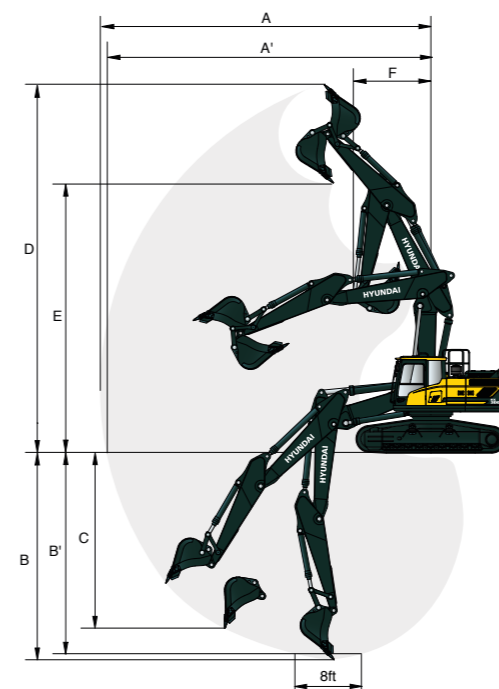

Boom length		6,250 (20' 6")			
Arm length		2,100 (6' 11")	2,500 (8' 2")	3,050 (10' 0")	3,750 (12' 4")
A	Max. digging reach	10,080 (33' 1")	10,360 (34' 0")	10,870 (35' 8")	11,500 (37' 9")
A'	Max. digging reach on ground	9,860 (32' 4")	10,150 (33' 4")	10,670 (35' 0")	11,310 (37' 1")
B	Max. digging depth	5,870 (19' 3")	6,220 (20' 5")	6,760 (22' 2")	7,440 (24' 5")
B'	Max. digging depth (8' level)	5,760 (18' 11")	6,120 (20' 1")	6,670 (21' 11")	7,350 (24' 1")
C	Max. vertical wall digging depth	4,950 (16' 3")	5,150 (16' 11")	5,690 (18' 8")	6,390 (21' 0")
D	Max. digging height	11,590 (38' 0")	11,730 (38' 6")	12,140 (39' 10")	12,600 (41' 4")
E	Max. dumping height	8,360 (27' 5")	8,500 (27' 11")	8,910 (29' 3")	9,370 (30' 9")
F	Min. front swing radius	3,200 (10' 6")	2,920 (9' 7")	2,650 (8' 8")	2,870 (9' 5")

BUCKET SELECTION GUIDE & DIGGING FORCE

BUCKETS

All buckets are welded with high-strength steel.



SAE heaped m ³ (yd ³)	1.27 (1.66)	◆ 1.27 (1.66)	◆ 1.28 (1.67)	■ 1.33 (1.74)	★ 0.52 (0.68)	0.55 (0.72)
	1.50 (1.96)	◆ 1.46 (1.91)		■ 1.50 (1.96)		
	1.73 (2.26)					
	1.85 (2.42)					

Capacity m ³ (yd ³)		Width mm (in)		Weight kg (lb)	Tooth EA	Recommendation mm (ft.in)									
						Mono				2pcs			L/Reach		
SAE heaped	CECE heaped	Without side cutters	With side cutters			6,250 (20' 6") Boom				6,250 (20' 6") 2-Piece Boom			10,200 (33' 6") Boom		
						2,100 Arm	2,500 Arm	3,050 Arm	3,750 Arm	2,100 Arm	2,500 Arm	3,050 Arm	7,850 Arm		
1.27 (1.66)	1.11 (1.45)	1,325 (52)	1,410 (55.5)	1,135 (2,500)	5	●	●	○	■	●	●	●	-		
1.50 (1.96)	1.30 (1.70)	1,515 (60)	1,600 (63.0)	1,225 (2,700)	5	○	○	■	▲	●	●	○	-		
1.73 (2.26)	1.51 (1.98)	1,605 (63)	1,690 (66.5)	1,310 (2,890)	6	■	■	▲	-	○	○	■	-		
1.85 (2.42)	1.61 (2.11)	1,700 (67)	1,780 (70.1)	1,355 (2,990)	6	■	▲	▲	-	○	○	■	-		
◆ 1.27 (1.66)	1.11 (1.45)	1,380 (54)	-	1,305 (2,880)	5	●	●	○	■	●	●	●	-		
◆ 1.46 (1.91)	1.28 (1.67)	1,535 (60)	-	1,395 (3,080)	5	○	○	■	▲	●	●	○	-		
◆ 1.28 (1.67)	1.12 (1.46)	1,230 (48)	1,300 (51)	1,285 (2,830)	5	●	●	○	■	●	●	●	-		
■ 1.33 (1.74)	1.16 (1.52)	1,420 (56)	-	1,490 (3,280)	5	○	○	■	▲	●	●	○	-		
■ 1.50 (1.96)	1.30 (1.70)	1,550 (61)	-	1,575 (3,470)	5	■	■	▲	▲	●	●	○	-		
★ 0.52 (0.68)	0.45 (0.59)	945 (37)	1,020 (40.2)	470 (1,040)	5	-	-	-	-	-	-	-	■		
● 0.55 (0.72)	0.45 (0.59)	1,800 (71)	-	590 (1,300)	-	-	-	-	-	-	-	-	▲		

- ◆ Heavy duty bucket
- Rock-Heavy duty bucket
- ★ Long reach bucket
- Slope finishing bucket
- Applicable for materials with density of 2,100 kgf/m³ (3,500 lbf/yd³) or less
- Applicable for materials with density of 1,800 kgf/m³ (3,000 lbf/yd³) or less
- Applicable for materials with density of 1,500 kgf/m³ (2,500 lbf/yd³) or less
- ▲ Applicable for materials with density of 1,200 kgf/m³ (2,000 lbf/yd³) or less

ATTACHMENT



Booms and arms are welded with a low-stress, full-box section design, 6,250 mm (20' 6"), 10,200 mm (33' 6") Booms and 2,100 mm (6' 11"), 2,500 mm (8' 2"), 3,050 mm (10' 0"), 3,750 mm (12' 4"), 7,850 mm (25' 9"), Arms are available.

DIGGING FORCE

Boom	Length	mm (ft.in)	6,250 (20' 6")				10,200 (33' 6")	Remarks:
			2,780 (6,130)				3,530 (7,780)	
Arm	Length	mm (ft.in)	2,100 (6' 11")	2,500 (8' 22")	3,050 (10' 0")	3,750 (12' 4")	7,850 (25' 9")	
			Weight					
Bucket digging force	SAE	kN	164.8 [179.8]	165.7 [180.8]	165.7 [180.8]	166.7 [181.9]	70.6	[]: Power Boost
		kgf	16,800 [18,330]	16,900 [18,440]	16,900 [18,440]	17,000 [18,550]	7,200	
		lbf	37,040 [40,410]	37,260 [40,650]	37,260 [40,650]	37,480 [40,900]	15,870	
	ISO	kN	191.2 [208.6]	191.2 [208.6]	192.2 [209.7]	192.2 [209.7]	82.4	
		kgf	19,500 [21,270]	19,500 [21,270]	19,600 [21,380]	19,600 [21,380]	8,400	
		lbf	42,990 [46,890]	42,990 [46,890]	43,210 [47,130]	43,210 [47,130]	18,520	
Arm crowd force	SAE	kN	180.4 [196.8]	155.9 [170.1]	131.4 [143.4]	114.7 [125.1]	47.1	
		kgf	18,400 [20,070]	15,900 [17,350]	13,400 [14,620]	11,700 [12,780]	4,800	
		lbf	40,570 [44,250]	35,050 [38,250]	29,540 [32,230]	25,790 [28,130]	10,580	
	ISO	kN	190.3 [207.5]	163.8 [178.7]	136.3 [148.7]	119.6 [130.5]	48.1	
		kgf	19,400 [21,160]	16,700 [18,220]	13,900 [15,160]	12,200 [13,310]	4,900	
		lbf	42,770 [46,650]	36,820 [40,170]	30,640 [33,420]	26,900 [29,340]	10,800	













Note : Boom weight includes arm cylinder, piping, and pin. Arm weight includes bucket cylinder, linkage, and pin

LIFTING CAPACITY

 Rating over-front  Rating over-side or 360 degrees



HX300AL HIGH WALKER

6.25 m (20' 6") boom, 2.5 m (8' 2") arm equipped with 5,100 kg counter weight and 700 mm (28") Double grouser shoe.

Lift-point height m (ft)	Lift-point radius										At max. Reach			
	1.5 m (4.9 ft)		3.0 m (9.8 ft)		4.5 m (14.8 ft)		6.0 m (19.7 ft)		7.5 m (24.6 ft)		Capacity		Reach	
													m (ft)	
7.5 m (24.6 ft)	kg											*6,650	*6,650	7.01 (23.0)
	lb											*14,660	*14,660	
6.0 m (19.7 ft)	kg							*7,970	*7,970	*7,440	7,330	*6,410	*6,410	7.90 (25.9)
	lb							*17,570	*17,570	*16,400	16,160	*14,130	*14,130	
4.5 m (14.8 ft)	kg					*11,840	*11,840	*9,090	*9,090	*7,860	7,130	*6,450	5,880	8.43 (27.7)
	lb					*26,100	*26,100	*20,040	*20,040	*17,330	15,720	*14,220	12,960	
3.0 m (9.8 ft)	kg							*10,360	9,480	*8,470	6,850	*6,730	5,470	8.67 (28.4)
	lb							*22,840	20,900	*18,670	15,100	*14,840	12,060	
1.5 m (4.9 ft)	kg					*13,230	*13,230	*11,320	9,000	*9,000	6,580	*7,290	5,340	8.64 (28.3)
	lb					*29,170	*29,170	*24,960	19,840	*19,840	14,510	*16,070	11,770	
Ground Line	kg					*15,970	*15,970	*11,740	8,680	9,140	6,370	7,830	5,500	8.33 (27.3)
	lb					*35,210	*35,210	*25,880	19,140	20,150	14,040	17,260	12,130	
-1.5 m (-4.9 ft)	kg		*13,230	*13,230	*15,270	*15,270	*11,490	8,520	*8,890	6,270		*8,520	6,030	7.72 (25.3)
	lb		*29,170	*29,170	*33,660	*33,660	*25,330	18,780	*19,600	13,820		*18,780	13,290	
-3.0 m (-9.8 ft)	kg		*18,360	*18,360	*13,660	*13,660	*10,300	8,530				*8,780	7,310	6.72 (22.1)
	lb		*40,480	*40,480	*30,120	*30,120	*22,710	18,810				*19,360	16,120	
-4.5 m (-14.8 ft)	kg				*10,160	*10,160						*8,640	*8,640	5.10 (16.7)
	lb				*22,400	*22,400						*19,050	*19,050	















- Lifting capacity is based on ISO 10567.
- Lifting capacity of HX Series does not exceed 75% of tipping load with the machine on firm, level ground or 87% of full hydraulic capacity.
- The Lift-point is bucket pivot mounting pin on the arm (without bucket mass).
- (*) indicates load limited by hydraulic capacity.

LIFTING CAPACITY

 Rating over-front  Rating over-side or 360 degrees

HX300AL HIGH WALKER

6.25 m (20' 6") boom, 3.75 m (12' 4") arm equipped with 5,100 kg counter weight and 700 mm (28") Double grouser shoe.

Lift-point height m (ft)	Lift-point radius												At max. Reach					
	1.5 m (4.9 ft)		3.0 m (9.8 ft)		4.5 m (14.8 ft)		6.0 m (19.7 ft)		7.5 m (24.6 ft)		9.0 m (29.5 ft)		Capacity		Reach			
															m (ft)			
9.0 m (29.5 ft)	kg														*3,720	*3,720	7.21 (23.6)	
	lb														*8,200	*8,200		
7.5 m (24.6 ft)	kg													*5,440	*5,440		8.36 (27.4)	
	lb													*11,990	*11,990			
6.0 m (19.7 ft)	kg													*6,110	*6,110	*3,880	*3,880	9.12 (29.9)
	lb													*13,470	*13,470	*8,550	*8,550	
4.5 m (14.8 ft)	kg													*7,560	*7,560	*6,730	*6,730	9.58 (31.4)
	lb													*16,670	*16,670	*14,840	*14,840	
3.0 m (9.8 ft)	kg													*12,100	*12,100	*9,010	*9,010	9.79 (32.1)
	lb													*26,680	*26,680	*19,860	*19,860	
1.5 m (4.9 ft)	kg													*14,450	14,030	*10,330	9,200	9.76 (32.0)
	lb													*31,860	30,930	*22,770	20,280	
Ground Line	kg																	9.49 (31.1)
	lb																	
-1.5 m (-4.9 ft)	kg	*7,940	*7,940	*11,560	*11,560	*15,740	12,960	*11,530	8,460	8,930	6,170				*4,950	4,790	8.96 (29.4)	
	lb	*17,500	*17,500	*25,490	*25,490	*34,700	28,570	*25,420	18,650	19,690	13,600				*10,910	10,560		
-3.0 m (-9.8 ft)	kg	*12,090	*12,090	*16,810	*16,810	*15,010	12,840	*11,160	8,330	*8,620	6,080				*6,300	5,460	8.12 (26.6)	
	lb	*26,650	*26,650	*37,060	*37,060	*33,090	28,310	*24,600	18,360	*19,000	13,400				*13,890	12,040		
-4.5 m (-14.8 ft)	kg	*17,320	*17,320	*18,640	*18,640	*13,160	12,930	*9,740	8,370						*8,050	6,970	6.85 (22.5)	
	lb	*38,180	*38,180	*41,090	*41,090	*29,010	28,510	*21,470	18,450						*17,750	15,370		
-6.0 m (-19.7 ft)	kg																	4.80 (15.8)
	lb																	

- Lifting capacity is based on ISO 10567.
- Lifting capacity of HX Series does not exceed 75% of tipping load with the machine on firm, level ground or 87% of full hydraulic capacity.
- The Lift-point is bucket pivot mounting pin on the arm (without bucket mass).
- (*) indicates load limited by hydraulic capacity.

LIFTING CAPACITY



HX300AL HIGH WALKER LONG REACH

102.0 m (33' 6") boom, 7.85 m (25' 9") arm equipped with 7,000 kg counter weight and 700 mm (28") Double grouser shoe.

Lift-point height m (ft)	Lift-point radius																						
	1.5 m (4.9 ft)		3.0 m (9.8 ft)		4.5 m (14.8 ft)		6.0 m (19.7 ft)		7.5 m (24.6 ft)		9.0 m (29.5 ft)												
13.5 m (44.3 ft)	kg												lb										
12.0 m (39.4 ft)	kg												lb										
10.5 m (34.4 ft)	kg												lb										
9.0 m (29.5 ft)	kg												lb										
7.5 m (24.6 ft)	kg												lb										
6.0 m (19.7 ft)	kg												lb										
4.5 m (14.8 ft)	kg												lb										
3.0 m (9.8 ft)	kg					*8,610	*8,610	*6,030	*6,030	*4,750	*4,750	*4,000	lb			*18,980	*18,980	*13,290	*13,290	*10,470	*10,470	*8,820	*8,820
1.5 m (4.9 ft)	kg					*3,650	*3,650	*7,380	*7,380	*5,610	*5,610	*4,590	lb			*8,050	*8,050	*16,270	*16,270	*12,370	*12,370	*10,120	*10,120
Ground Line	kg					*1,380	*1,380	*3,010	*3,010	*6,720	*6,720	*6,350	lb			*3,040	*3,040	*6,640	*6,640	*14,820	*14,820	*14,000	*11,270
-1.5 m (-4.9 ft)	kg	*1,470	*1,470	*1,950	*1,950	*3,210	*3,210	*5,850	*5,850	*6,910	6,160	*5,550	lb	*3,240	*3,240	*4,300	*4,300	*7,080	*7,080	*12,900	*12,900	13,580	*12,240
-3.0 m (-9.8 ft)	kg	*2,110	*2,110	*2,600	*2,600	*3,720	*3,720	*5,950	*5,950	*7,310	5,940	*5,880	lb	*4,650	*4,650	*5,730	*5,730	*8,200	*8,200	*13,120	*13,120	13,100	*12,960
-4.5 m (-14.8 ft)	kg	*2,770	*2,770	*3,310	*3,310	*4,400	*4,400	*6,510	*6,510	*7,530	5,830	*6,100	lb	*6,110	*6,110	*7,300	*7,300	*9,700	*9,700	*14,350	*14,350	12,850	*13,450
-6.0 m (-19.7 ft)	kg	*3,480	*3,480	*4,090	*4,090	*5,240	*5,240	*7,400	*7,400	*7,580	5,810	*6,180	lb	*7,670	*7,670	*9,020	*9,020	*11,550	*11,550	*16,310	*16,310	12,810	*13,620
-7.5 m (-24.6 ft)	kg	*4,240	*4,240	*4,970	*4,970	*6,260	*6,260	*8,660	8,060	*7,470	5,850	*6,120	lb	*9,350	*9,350	*10,960	*10,960	*13,800	*13,800	*19,090	17,770	*16,470	12,900
-9.0 m (-29.5 ft)	kg	*5,100	*5,100	*5,980	*5,980	*7,530	*7,530	*8,940	8,240	*7,150	5,960	*5,890	lb	*11,240	*11,240	*13,180	*13,180	*16,600	*16,600	*19,710	18,170	*15,760	13,140
-10.5 m (-34.4 ft)	kg	*6,080	*6,080	*7,210	*7,210	*9,200	*9,200	*8,150	*8,150	*6,560	6,160	*5,390	lb	*13,400	*13,400	*15,900	*15,900	*20,280	*20,280	*17,970	*17,970	*14,460	13,580
-12.0 m (-39.4 ft)	kg					*8,780	*8,780	*8,810	*8,810	*6,870	*6,870	*5,530	lb			*19,360	*19,360	*19,420	*19,420	*15,150	*15,150	*12,190	*12,190

1. Lifting capacity is based on ISO 10567.
 2. Lifting capacity of HX Series does not exceed 75% of tipping load with the machine on firm, level ground or 87% of full hydraulic capacity.
 3. The Lift-point is bucket pivot mounting pin on the arm (without bucket mass).
 4. (*) indicates load limited by hydraulic capacity.

Lift-point height m (ft)	Lift-point radius										At max. Reach												
	10.5 m (34.4 ft)		12.0 m (39.4 ft)		13.5 m (44.3 ft)		15.0 m (49.2 ft)		16.5 m (54.1 ft)		Capacity	Reach											
													m (ft)										
13.5 m (44.3 ft)	kg												lb										
12.0 m (39.4 ft)	kg												lb										
10.5 m (34.4 ft)	kg												lb										
9.0 m (29.5 ft)	kg												lb										
7.5 m (24.6 ft)	kg												lb										
6.0 m (19.7 ft)	kg												lb										
4.5 m (14.8 ft)	kg												lb										
3.0 m (9.8 ft)	kg												lb										
1.5 m (4.9 ft)	kg												lb										
Ground Line	kg												lb										
-1.5 m (-4.9 ft)	kg	*4,660	3,940	*4,030	3,270	*3,590	2,750	*2,700	2,340	*1,330	*1,330	*970	lb	*10,270	8,690	*8,880	7,210	*7,910	6,060	*5,950	5,160	*2,930	*2,930
-3.0 m (-9.8 ft)	kg	*4,920	3,800	*4,240	3,160	*3,740	2,680	*2,670	2,290			*1,080	lb	*10,850	8,380	*9,350	6,970	*8,250	5,910	*5,890	5,050		
-4.5 m (-14.8 ft)	kg	*5,100	3,710	*4,390	3,100	*3,850	2,630	*2,350	2,270			*1,240	lb	*11,240	8,180	*9,680	6,830	*8,490	5,800	*5,180	5,000		
-6.0 m (-19.7 ft)	kg	*5,190	3,680	*4,450	3,070	*3,870	2,620	*1,550	*1,550			*1,450	lb	*11,440	8,110	*9,810	6,770	8,530	5,780	*3,420	*3,420		
-7.5 m (-24.6 ft)	kg	*5,140	3,690	*4,390	3,090	*3,000	2,650					*1,770	lb	*11,330	8,140	*9,680	6,810	*6,610	5,840				
-9.0 m (-29.5 ft)	kg	*4,940	3,760	*4,160	3,170							*2,300	lb	*10,890	8,290	*9,170	6,990						
-10.5 m (-34.4 ft)	kg	*4,450	3,910									*3,320	lb	*9,810	8,620								
-12.0 m (-39.4 ft)	kg											*4,180	lb										

1. Lifting capacity is based on ISO 10567.
 2. Lifting capacity of HX Series does not exceed 75% of tipping load with the machine on firm, level ground or 87% of full hydraulic capacity.
 3. The Lift-point is bucket pivot mounting pin on the arm (without bucket mass).
 4. (*) indicates load limited by hydraulic capacity.

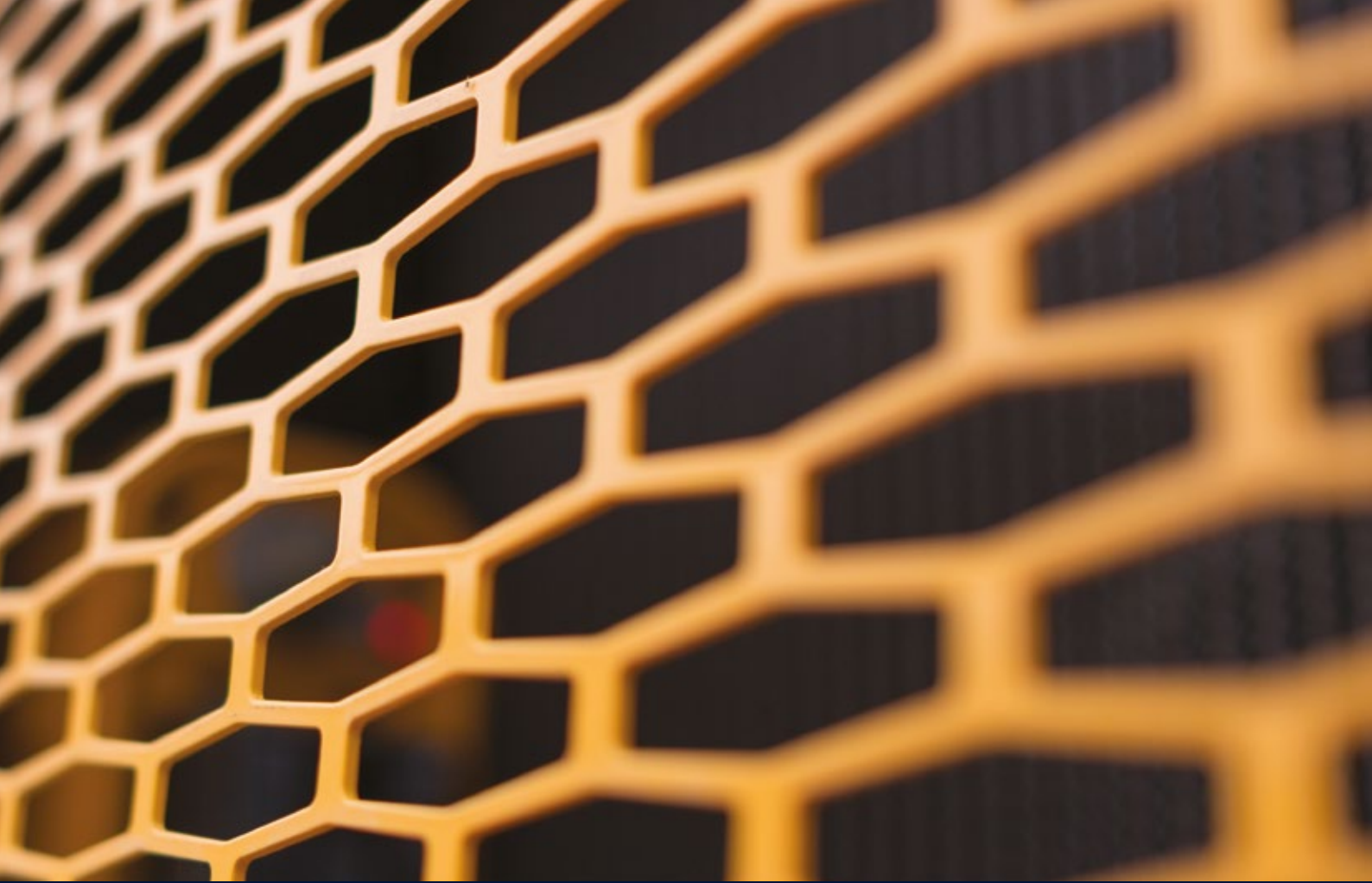

Specifications and design are subject to change without notice. Pictures of Hyundai Construction Equipment Europe products may show other than standard equipment.

Hyundai Construction Equipment Europe nv, Hyundailaan 4, 3980 Tessenderlo, Belgium. Tel: (32) 14-56-2200 Fax: (32) 14-59-3405

EN - 2020.01 Rev 1

Ready to experience the Hyundai Effect?

Contact your Hyundai dealer.

hyundai-ce.eu/en/dealer-locator

