

# AIRGO



BREAKER & HAMMER  
NEW GENERATION

MADE IN FRANCE

## BORN TO CHANGE THE RULES

### WORKING EFFICIENCY & COMFORT NEVER EQUALLED

**50% LESS VIBRATION**  
REDUCTION OF ARDUOUSNESS AND MSDs\*  
\* MusculoSkeletal Disorders

**40% ENERGY SAVING**  
LOW COMPRESSED AIR CONSUMPTION

**0% LUBRICATION FOR OPERATION**  
OPTIMIZED USE AND MAINTENANCE

**40% LESS PARTS IN ACTION**  
REINFORCED RELIABILITY

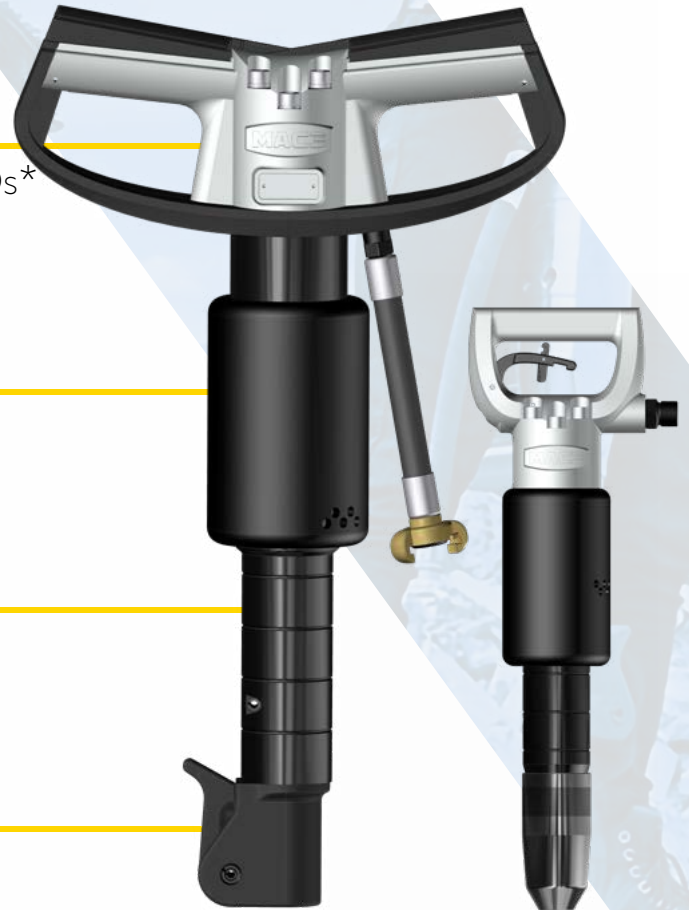

## SPECIFICATIONS

Model	Weight kg - lb	Vibration level m/s <sup>2</sup>	Air consumption l/min - cfm	Shank size mm - in.
AIRGO 9D*	10 - 22	4	1 000 - 35,1	26 x 70 - 1 <sup>1</sup> / <sub>32</sub> " x 2 <sup>3</sup> / <sub>4</sub> "
AIRGO 9D*	10 - 22	4	1 000 - 35,1	25 x 75 - 1" x 3"
AIRGO 9D*	10 - 22	4	1 000 - 35,1	23 x 70 - 2 <sup>9</sup> / <sub>32</sub> " x 2 <sup>3</sup> / <sub>4</sub> "
AIRGO 9D*	10 - 22	4	1 000 - 35,1	Latch 22 x 82 - 7 <sup>8</sup> / <sub>8</sub> " x 3 <sup>1</sup> / <sub>4</sub> "
AIRGO 13D*	14 - 30,8	4,2	1 200 - 42,4	26 x 70 - 1 <sup>1</sup> / <sub>32</sub> " x 2 <sup>3</sup> / <sub>4</sub> "
AIRGO 13D*	14 - 30,8	4,2	1 200 - 42,4	25 x 75 - 1" x 3"
AIRGO 20T	21 - 46,3	5	1 200 - 42,4	22 x 82 - 7 <sup>8</sup> / <sub>8</sub> " x 3 <sup>1</sup> / <sub>4</sub> "
AIRGO 20T	21 - 46,3	5	1 200 - 42,4	25 x 108 - 1" x 4 <sup>1</sup> / <sub>4</sub> "

\* Available from: september 2020

# DESIGN

## AIRGO RANGE

Equipped with the latest MAC3 innovations, AIRGO **retains fixed handles**, while ensuring a vibration level on 3 axes less than  $5 \text{ m/s}^2$

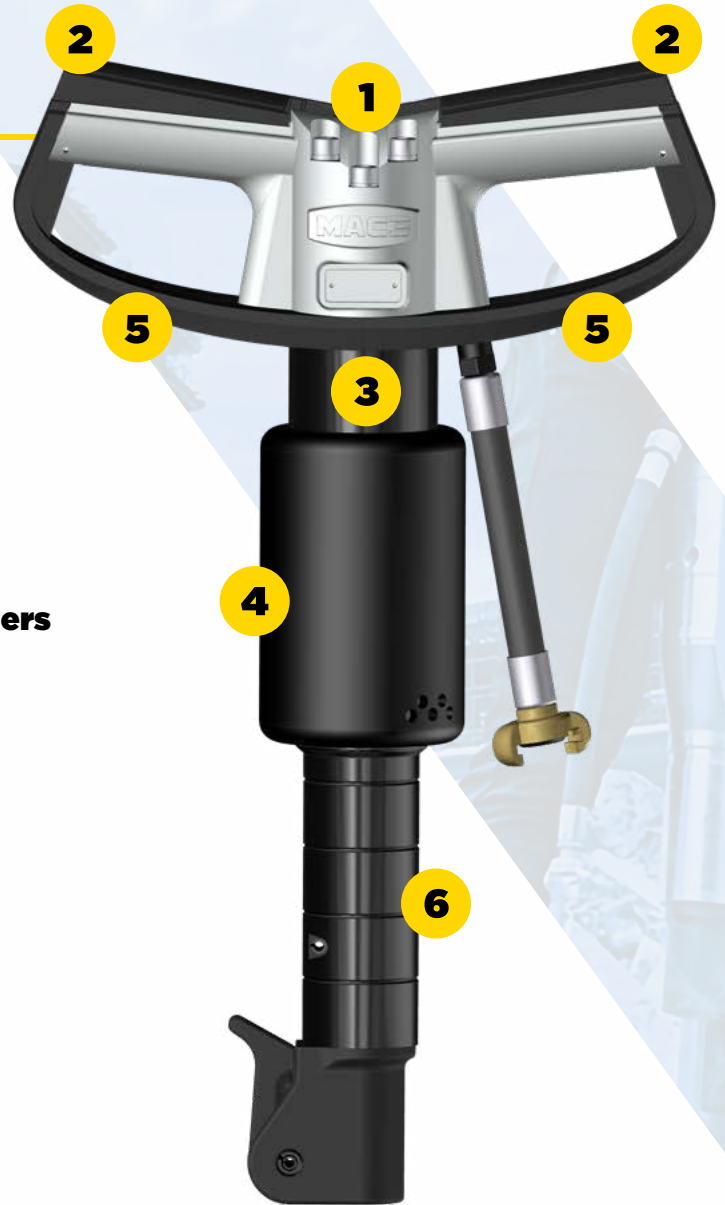

- 1 Fixed handle**
  - More precise work
- 2 Ambidexterity handle**  
**Safety system incorporated in the triggers**
- 3 Patented vibration reduced technology**
- 4 Silent reducing noise pollution by 50%**
- 5 Hands protection**
- 6 Lightweight and ergonomic design**

**COMPRESSED AIR**  
SOLUTIONS



DISTRIBUTED BY:

**MAC3**

10 allée du canal  
ZC des Landes  
42160 Saint-Cyprien  
FRANCE

Tel : +33 (0)4 77 02 13 08  
Fax : +33 (0)4 77 02 20 28  
contact@mac3.fr

